



Investigative Energy Audit  
For  
Alaska Tribal Cache (ATC) Building



Prepared For  
**Seldovia Village Tribe**

Prepared By  
**Curtis Boudreau, PE, CEM**

**April 3, 2017**

**Prepared By:**

**ANTHC-DEHE  
4500 Diplomacy Dr.  
Anchorage, AK 99508**

## Table of Contents

PREFACE .....	2
ACKNOWLEDGMENTS .....	2
OVERVIEW .....	3
ENERGY BASELINE .....	3
PROPOSED ENERGY EFFICIENCY MEASURES (EEM) .....	4
FACILITY DESCRIPTION .....	5
PROJECT FINANCING .....	7
MEASUREMENT AND VERIFICATION .....	7
Appendix A – Scanned Energy Billing Data .....	8
Appendix B – Energy Audit Report – Project Summary .....	9
Appendix C – Actual Fuel Use versus Modeled Fuel Use .....	10
Appendix D - EUI Calculation Details .....	11
Appendix E – Materials List and Labor Estimation.....	12
Appendix F – Materials Specifications .....	13

## PREFACE

The purpose of this report is to provide guidance in reducing facility operating costs and enhance the sustainability of this community. The report assess the current energy usage of the facility, provide options for reducing the amount of energy used, and evaluate the cost vs. benefit of each option.

Discussions of site specific concerns, financing options, general facility information, and an Energy Efficiency Action Plan are also included in this report.

## ACKNOWLEDGMENTS

The Energy Projects Group gratefully acknowledges the assistance of the Seldovia Village Tribe’s Facility Director, Bob Wabach, and Maintenance Technician, Juan Botero.

# OVERVIEW

This report was prepared for the Seldovia Village Tribe. The scope of the audit focused on the ATC Building and includes an analysis of building occupancy schedules, building shell, heating systems, heating and ventilations systems, domestic hot water, lighting, and other electrical loads. The ATC Building was last renovated around 2004 and is approximately 11,593 square feet. The building was originally constructed to support a local cannery operation, was later modified to serve as a local grocery store, and is now used as a multi-purpose building. The building houses a local pre-school, commercial kitchen, workout facility, dry storage, offices, and larger conference space. Data was based on a site survey and interviews with the building manager and maintenance staff.

## ENERGY BASELINE

Based on unsubsidized electricity and fuel oil prices in effect at the time of the audit, the total predicted energy costs are \$20,280 per year. This includes \$12,873 for electricity and \$7,407 for #1 fuel oil.

Table 1 lists the predicted annual energy usage before and after the proposed retrofits.

**Annual Energy Costs By Fuel**

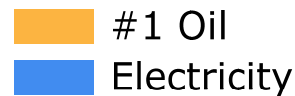
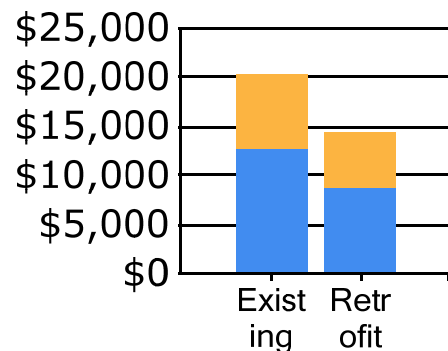

**Table 1: Predicted Annual Energy Use**

Predicted Annual Energy Use				
Fuel Use	Existing Building	With Proposed Retrofits	Total Energy Savings	Total Cost Savings
Electricity	55,133 kWh	37,148 kWh	17,985 kWh	\$4,121
#1 Oil	2,166 gallons	1,667 gallons	499 gallons	\$1707

## PROPOSED ENERGY EFFICIENCY MEASURES (EEM)

Table 2 below summarizes the energy efficiency measures analyzed for the Building. Listed are the estimates of the annual savings, installed costs, and two different financial measures of investment return.

**Table 2: Priority List – Energy Efficiency Measures**

Priority	Feature	Improvement Description	Cost Estimate	Annual Energy Savings	Installed Cost	Savings to Investment Ratio, SIR <sup>1</sup>	Simple Payback (Years) <sup>2</sup>
1	Install programmable thermostats	Program Thermostats to turn building temperature down to 55 deg F after-hours	Materials: \$50/thermostat Labor: \$50/thermostat Contingency: 10% Quantity: 22 thermostats	\$3,166	\$2,200	18.51	0.7
2	Seal around exterior doors	Install weather stripping around exterior doors and attic access hatches to reduce air leakage by 25%	Material 1: \$32/ man-door Material 2: \$160/garage door Material 3: \$6/access hatch Labor: Maintenance Staff Contingency: 10% Quantity 1: 9 man doors Quantity 2: 1 garage door Quantity 3: 2 access hatches	\$461	\$500	8.26	1.1
3	Replace glass-front commercial fridge	Remove glass front fridge and replace with energy-star rated fridge	Materials: \$2,000	\$441	\$2,000	1.34	4.5
4	Retrofit LED bulbs in 4-bulb T8 light fixtures	Replace fluorescent bulbs with LED and remove ballasts in all 4-bulb t8 fixtures	Materials: \$12/bulb Labor: \$20/fixture Contingency: 10% Quantity: 50 fixtures	\$849	\$4,000	1.30	4.7
5	Retrofit LED bulbs in 6-bulb T8 light fixtures	Replace fluorescent bulbs with LED and remove ballasts in all 6-bulb t8 fixtures	Materials: \$12/bulb Labor: \$20/fixture Contingency: 10% Quantity: 12 fixtures	\$256	\$1,300	1.19	5.1
6	Retrofit LED bulbs in 2-bulb T8 light fixtures	Replace fluorescent bulbs with LED and remove ballasts in all 2-bulb t8 fixtures	Materials: \$12/bulb Labor: \$20/fixture Contingency: 10% Quantity: 80 fixtures	\$655	\$4,000	1.00	6.1
<b>TOTAL</b>				<b>\$5,828</b>	<b>\$14,000</b>	<b>4.16</b>	<b>2.4</b>

<sup>1</sup> Savings to Investment Ratio (SIR) is a life-cycle cost measure calculated by dividing the total savings over the life of a project (expressed in today's dollars) by its investment costs. The SIR is an indication of the profitability of a measure; the higher the SIR, the more profitable the project. An SIR greater than 1.0 indicates a cost-effective project (i.e. more savings than cost). Remember that this profitability is based on the position of that Energy Efficiency Measure (EEM) in the overall list and assumes that the measures above it are implemented first.

<sup>2</sup> Simple Payback (SP) is a measure of the length of time required for the savings from an EEM to payback the investment cost, not counting interest on the investment and any future changes in energy prices. It is calculated by dividing the investment cost by the expected first-year savings of the EEM.

# FACILITY DESCRIPTION

## Building Occupancy Schedules

The building is occupied year-round from 8:00am-5:00pm every day by approximately 6 office staff. The daycare center on the lower floor is utilized approximately 4 hours a day on weekdays. There is a large commercial kitchen that serves meals seasonally and the occupancy and energy usage varies widely. There is a large area with exercise equipment that is occasionally used during the evening hours. A large conference room is located on the upper level and is used occasionally. There are large heated and unheated storage spaces as well that are infrequently occupied.

## Building Shell

The exterior walls are 2x6 wood-framed panel construction.

The roof of the building is a structural truss with a cold attic space. There were 2 attic access hatches into the attic space that are in need of air sealing.

The building is constructed on a concrete slab foundation.

There are approximately 43 total windows in the building, each of which is approximately 4.5 feet tall and vary widely in width. The windows are double-pane glass. The operable windows have a horizontal sliding pane with brush air seals. There was some leakage measured around the windows, but any measures to address the leaks would require opening up the building wall and the cost would not justify the savings.

There are 9 entrances into the building, most of which have significant amounts of glass in them. All doors were noticeably leaking air when tested with the blower door and require air sealing.

There is a rolling garage door entrance into the main storage area of the building that has a very significant air leak on the top edge of the door.

## Heating Systems

The heating systems used in the building are:

### **Boiler 1**

Fuel Type:	#1 Oil
Input Rating:	212,000 BTU/hr
Steady State Efficiency:	84 %
Idle Loss:	3.0 %
Heat Distribution Type:	Water
Boiler Operation:	9 Months/Year

## **Boiler 2**

Fuel Type:	#1 Oil
Input Rating:	212,000 BTU/hr
Steady State Efficiency:	84 %
Idle Loss:	3.0 %
Heat Distribution Type:	Water
Boiler Operation:	9 Months/Year

Several of the offices in the building were not able to maintain an acceptable indoor air temperature and had portable electric space heaters installed for supplementary heat. Additionally, there are 8 different refrigerators/freezers in the building as well as commercial cooking equipment, a utility transformer, and numerous appliances that add heat to the facility.

### **Space Heating Distribution Systems**

The building is heated by a baseboard heating system that circulates hot water around the building. The building has several heating zones that are controlled by individual thermostats. The space interior temperature varies significantly throughout the building with the rooms on the lower floor with high air leakage being the coolest and the storage room adjacent to the boiler room being the warmest.

### **Building Ventilation Systems**

The building relies on operable windows and bathroom exhaust fans for ventilation.

### **Domestic Hot Water System**

Domestic hot water for the building is provided by a hot water heater with an approximate capacity of 40 gallons. The heater is indirectly heated by the 2 boilers.

### **Lighting**

The interior space is lit with 142 fluorescent T8 light fixtures. 80 of the fixtures have 2 bulbs each, 50 have 4 bulbs each, and 12 have 6 bulbs each. The lights use an estimated 28,833 kWh annually.

### **Other Electrical Loads**

There are a total of 8 refrigerators/freezers of various sizes as well as exercise equipment, computers, and kitchen accessories that draw significant amounts of energy when in use. There is also a large utility transformer located in the boiler room that produced a significant amount of heat.

## **Major Equipment**

**Table 3: Major Electrical Equipment**

<b>Equipment</b>	<b>Rating (Watts)</b>	<b>Approx. Annual Usage (kWh)</b>
Commercial Fridge		3338
Standard Fridge	~500	3500
Treadmill	~1,500	652
Microwave	~1,000	130
Desktop Computers	~125	2,935

## **PROJECT FINANCING**

The total estimated cost of the recommended EEM's \$14,000. The payback for the implemented EEM's is approximately 2.4 years. ANTHC is willing to assist the community with acquiring funds to complete the scope of work recommended in this energy audit.

There are several options for financing energy efficiency projects within the State of Alaska. These include the use of grants, loans, and other funding opportunities. Below is some information on potential funding opportunities.

**Energy Efficiency Revolving Loan Program** – This is a loan administered by the Alaska Housing Finance Corporation (AHFC) for use by any applicant who is also the owner of the building where the work will take place. It provides a loan for permanent energy-efficiency projects with a completion window of one year.

**Sustainable Energy Transmission and Supply Program** – This is a loan administered by the Alaska Energy Authority (AEA) for a government, business, or other organized body of people. It provides a loan for energy-efficiency or power transmission or distribution projects.

**USDA-RD Communities Facilities Direct Loan & Grant Program** - This is a loan or grant provided by the US Department of Agriculture – Rural Development (USDA-RD) for any essential community facility in a rural area. It provides a loan or grant to develop essential community facilities with upgrades or equipment for improvement.

## **MEASUREMENT AND VERIFICATION**

The results of these recommended measures can be measured through the collection of energy use data through the monthly bills provided by the local electric utility and the local fuel oil supplier. Collecting data and performing a historical comparison is the simplest method of validating the energy and cost savings seen by the measures. Additionally, active remote monitoring systems are available that can collect and store data regarding energy and fuel usage. These systems allow the user to track the usage in real time and can be shared more easily with partners across the state.

# APPENDICES

## Appendix A – Scanned Energy Billing Data

### 1. Electricity Billing Data

Electric	ID: Electric 2015	Notes:											Rate Schedule Type:	
	Jan	Feb	Mar	Apr	May	Jun	Jul	Aug	Sep	Oct	Nov	Dec	Annual	
Qty	6,360	5,252	5,280	5,463	6,080	4,840	4,680	5,040	4,760	4,720	4,452	5,800	62,727	kWh
kW Demand	0.0	0.0	0.0	0.0	0.0	0.0	0.0	0.0	0.0	0.0	0.0	0.0	0.0	
Cost	1,342	1,109	1,167	1,207	1,409	1,263	1,223	1,305	1,243	1,256	1,185	1,292	15,002	
Year	2015	2015	2015	2015	2015	2015	2015	2015	2015	2015	2015	2015		

### 2. #1 Fuel Oil Billing Data

#1 Fuel Oil	ID: Fuel 2016	Notes:											Rate Schedule Type:	
	Jan	Feb	Mar	Apr	May	Jun	Jul	Aug	Sep	Oct	Nov	Dec	Annual	
Qty	314	195	219	139	57	0	0	95	233	154	305	317	2,028	gallons
kW Demand	0.0	0.0	0.0	0.0	0.0	0.0	0.0	0.0	0.0	0.0	0.0	0.0	0.0	
Cost	1,195	742	832	530	218	0	0	362	809	535	1,057	1,098	7,378	
Year	2016	2016	2016	2016	2016	2016	2016	2016	2016	2016	2016	2016		



## Appendix B – Energy Audit Report – Project Summary

ENERGY AUDIT REPORT – PROJECT SUMMARY	
General Project Information	
<b>PROJECT INFORMATION</b>	<b>AUDITOR INFORMATION</b>
<b>Building:</b> SVT Cache	<b>Auditor Company:</b> ANTHC
<b>Address:</b> 328 Main Street	<b>Auditor Name:</b> Curtis Boudreau
<b>City:</b> Seldovia	<b>Auditor Address:</b>
<b>Client Name:</b> Connie Pavalof	<b>Auditor Phone:</b> (907) 729-3528
<b>Client Address:</b>	<b>Auditor FAX:</b>
<b>Client Phone:</b> (907) 435-3293	<b>Auditor Comment:</b>
<b>Client FAX:</b>	
Design Data	
<b>Building Area:</b> 11,593 square feet	<b>Design Space Heating Load:</b> Design Loss at Space: 70,784 Btu/hour with Distribution Losses: 70,784 Btu/hour Plant Input Rating assuming 82.0% Plant Efficiency and 25% Safety Margin: 107,903 Btu/hour Note: Additional Capacity should be added for DHW and other plant loads, if served.
<b>Typical Occupancy:</b> 10 people	<b>Design Indoor Temperature:</b> 70 deg F (building average)
<b>Actual City:</b> Seldovia	<b>Design Outdoor Temperature:</b> 4.8 deg F
<b>Weather/Fuel City:</b> Seldovia	<b>Heating Degree Days:</b> 9,588 deg F-days
Utility Information	
<b>Electric Utility:</b> Homer Electric Assn - Commercial - Sm	<b>Fuel Oil Provider:</b> Seldovia Fuel and Lube
<b>Average Annual Cost/kWh:</b> \$0.233/kWh	<b>Average Annual Cost/gal:</b> \$3.42/gal

Annual Energy Cost Estimate									
Description	Space Heating	Space Cooling	Water Heating	Ventilation Fans	Lighting	Refrigeration	Other Electrical	Service Fees	Total Cost
<b>Existing Building</b>	\$9,190	\$0	\$1,801	\$24	\$6,607	\$1,567	\$852	\$240	<b>\$20,280</b>
<b>With Proposed Retrofits</b>	\$6,073	\$0	\$2,150	\$24	\$4,189	\$923	\$852	\$240	<b>\$14,452</b>
<b>Savings</b>	\$3,116	\$0	-\$349	\$0	\$2,417	\$643	\$0	\$0	<b>\$5,828</b>

Building Benchmarks			
Description	EUI (kBtu/Sq.Ft.)	EUI/HDD (Btu/Sq.Ft./HDD)	ECI (\$/Sq.Ft.)
<b>Existing Building</b>	40.9	4.26	\$1.75
<b>With Proposed Retrofits</b>	29.9	3.12	\$1.25
EUI: Energy Use Intensity - The annual site energy consumption divided by the structure's conditioned area. EUI/HDD: Energy Use Intensity per Heating Degree Day. ECI: Energy Cost Index - The total annual cost of energy divided by the square footage of the conditioned space in the building.			

## Appendix C – Actual Fuel Use versus Modeled Fuel Use

The graphs below show the modeled energy usage results of the energy audit process compared to the actual energy usage report data. The model was completed using AkWarm modeling software. The orange bars show actual fuel use, and the blue bars are AkWarm’s prediction of fuel use.

### Annual Energy Use

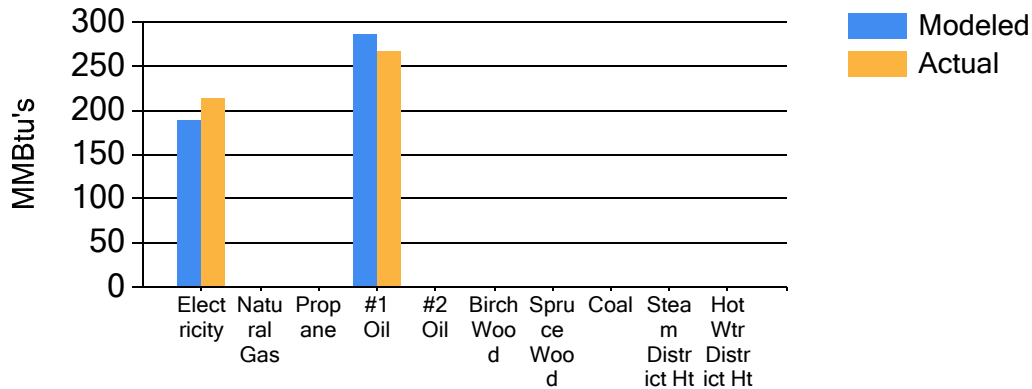

### Electricity Use

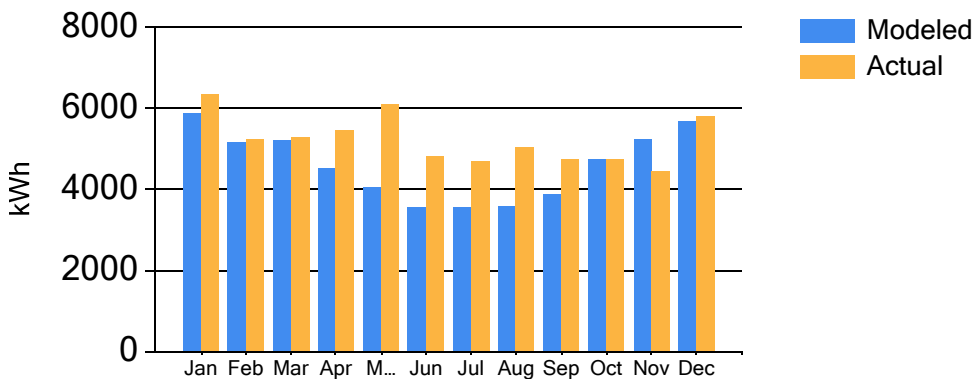

### #1 Fuel Oil Use

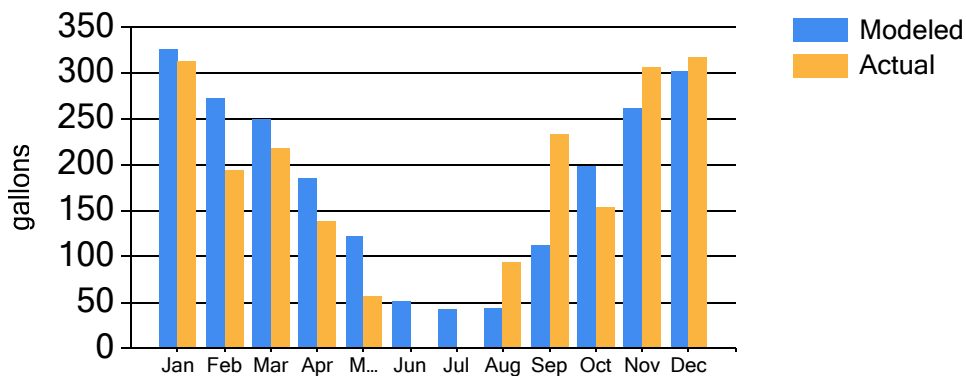

## Appendix D - EUI Calculation Details

The Homer Electric Association provides electricity to the residents of Seldovia as well as to all commercial and public facilities.

The average cost for each type of fuel used in this building is shown below in Table 4. This figure includes all surcharges, subsidies, and utility customer charges:

**Table 4: Energy Cost Rates for each Fuel Type.**

Average Energy Cost	
Description	Average Energy Cost
Electricity	\$ 0.233kWh
#1 Oil	\$ 3.42/gallons

Table 5 shows the calculated results for the building Energy Use Index (EUI), which determines the total energy usage for a type of building for comparison with other buildings of the same type. This allows the user to determine the relative energy use of a building in relation to others of the same type or use.

**Table 5: EUI Calculations**

Energy Type	Building Fuel Use per Year	Site Energy Use per Year, kBTU	Source/Site Ratio	Source Energy Use per Year, kBTU
Electricity	55,133 kWh	188,170	3.340	628,488
#1 Oil	2,166 gallons	285,880	1.010	288,739
<b>Total</b>		<b>474,050</b>		<b>917,227</b>
BUILDING AREA		11,593	Square Feet	
BUILDING SITE EUI		41	kBTU/Ft <sup>2</sup> /Yr	
<b>BUILDING SOURCE EUI</b>		<b>79</b>	<b>kBTU/Ft<sup>2</sup>/Yr</b>	
* Site – Source Ratio data is provided by the Energy Star Performance Rating Methodology for Incorporating Source Energy Use document issued March 2011.				

Table 6 shows information on common energy use benchmarks used to characterize the efficiency of a building.

**Table 6: Energy Efficiency Benchmarks for Building**

Building Benchmarks			
Description	EUI (kBtu/Sq.Ft.)	EUI/HDD (Btu/Sq.Ft./HDD)	ECI (\$/Sq.Ft.)
<b>Existing Building</b>	<b>40.9</b>	<b>4.26</b>	<b>\$1.75</b>
<b>With Proposed Retrofits</b>	<b>29.9</b>	<b>3.12</b>	<b>\$1.25</b>
EUI: Energy Use Intensity - The annual site energy consumption divided by the structure's conditioned area.			
EUI/HDD: Energy Use Intensity per Heating Degree Day.			
ECI: Energy Cost Index - The total annual cost of energy divided by the square footage of the conditioned space in the building.			

## Appendix E – Materials List and Labor Estimation

**Table 6 & 7: Materials List and Cost Estimation for Energy Improvements**

Energy Retrofit	Required Materials	Quantity	Cost per Item	Total Materials Cost
Setback Thermostat	Programmable Thermostat	22	\$50	\$1,100
Man-Door Weather Sealing	Door Sweep (3ft)	9	\$12	\$108
Man-Door Weather Sealing	Perimeter Gasket (17ft)	9	\$30	\$270
Garage Door Weather Sealing	Bottom Seal (16ft)	1	\$20	\$20
Garage Door Weather Sealing	Perimeter Sweeps (35 ft)	1	\$140	\$140
Attic Access Hatch Air Sealing	Perimeter Gasket	2	\$6	\$12
LED T8 Lighting	T8 LED Equivalent 4 ft.	432	\$12	\$5,184

## Appendix F – Materials Specifications



**4 FOOT**  
Fluorescent Replacement



**DIRECT WIRE**  
Ballast Bypass



**High Output**  
**LED**  
T8 | T12

**Performance Specifications**

REPLACEMENT FOR:	T8 OR T12 4 FOOT FLUORESCENT TUBE
BRIGHTNESS (LUMENS):	2400
COLOR TEMPERATURE:	4000K   5000K
COLOR ACCURACY (CRI):	80
DIMENSIONS	1.02" X 47.2"
POWER CONSUMPTION:	18 WATTS
VOLTAGE:	120-277 VOLTS
DIMMABLE:	NO

**Dimensions / Additional Data**

CERTIFICATIONS:	UL, DESIGNLIGHTS (DLC)
PRODUCT/ORDER CODE:	4000K - 18WT8P-4F-40K-BYP 5000K - 18WT8P-4F-50K-BYP

**Lifespan / Cost To Run**

PROJECTED LIFE: @3 HRS/DAY	50,000 HRS
YEARLY ENERGY COST: 3 HRS/DAY @ .11 KWH	\$2.17

<b>WARRANTY</b>	5 YEAR THINKLUX LIGHTING LIMITED WARRANTY EARTHLED PRODUCT PROTECTION PLAN IS AVAIL
-----------------	--

# Robertshaw®

## 9701i2



**Menu Driven Display**  
**7 Day Programmable with 2, 4 or 6 Events Per Day**  
**9701i2 - 1 Heat / 1 Cool**

**Worry-Free Memory Storage**  
Even during power outages, the thermostat maintains set point and programmed parameters.

## Man-Door Gasket for Top Sill and Side Jambs

### Pemko 303\_PK (PG) Standard Perimeter Gasketing

- Category J gaskets for use with listed steel frames and/or classified steel covered composite, hollow metal doors rated up to and including 3 hours; wood and plastic covered composite doors rated up to and including 1-1/2 hours; and wood core doors rated for 20 minutes.
- Rigid jamb weatherstrip is shown mounted on openings with 1/16" gaps; however, each weatherstrip can seal gaps up to the depth of its seal.
- Seal depth is provided on each illustration.
- Stainless Steel fasteners are standard.
- Other fasteners are available.
- Model 303\_ is available with self-adhesive, two-sided tape (TST) and tek screws (3 slotted holes per part) for easy installation.
- To obtain this option, add "TST" to the end of the part number when ordering (i.e. 303APK36TST).
- This perimeter gasketing is supplied with a PemkoPrene® ("PK") insert - item number PK47 (available in gray or black).

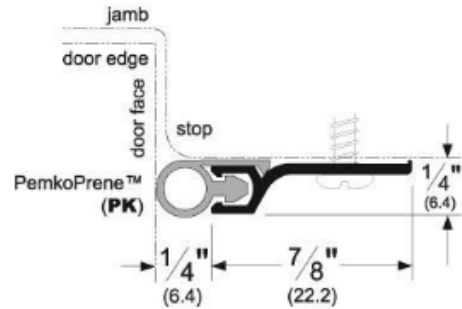

#### Ratings



Air Infiltration Tested



BHMA Certified



Smoke Tested - UL1784



Fire Rated - UL10C - Positive Pressure



Underwriters Laboratory 4L10



Environmental Product Declaration



Health Product Declaration

**Declare.** Declare



GREENGUARD Gold Certified

#### Finishes



**303APK:** A - Mill Finish Aluminum Aluminum with Gray PemkoPrene insert



**303BDGPK:** BDG - Bright Dip Gold Anodized Aluminum with Black PemkoPrene insert



**303CPK:** C - Clear Anodized Aluminum with Gray PemkoPrene insert



**303DPK:** D - Dark Bronze Anodized Aluminum with Black PemkoPrene insert



**303GPK:** G - Gold Anodized Aluminum with Black PemkoPrene insert



**303PWPK:** PW - Painted White Aluminum with Black PemkoPrene insert



**303SNPK:** SN - Satin Nickel Anodized Aluminum with Black PemkoPrene insert





## Man-Door Bottom Sweep

### Pemko 18062\_NB Brush Seal/180 Degree Aluminum Retainer





- This brush gasketing is supplied with a Nylon Brush ("NB") insert - item number P38062 (available in gray or black).
- Painted white insert is item number P516062W.

#### Ratings

**BHMA** BHMA Certified  
CERTIFIED

-  Smoke Tested - UL1784
-  Fire Rated - UL10C - Positive Pressure
-  Underwriters Laboratory 4L10
-  GREENGUARD Gold Certified

#### Finishes

-  **18062CNB:** C - Clear Anodized Aluminum with Gray Nylon Brush insert
-  **18062DNB:** D - Dark Bronze Anodized Aluminum with Black Nylon Brush insert
-  **18062GNB:** G - Gold Anodized Aluminum with Black Nylon Brush insert
-  **18062PWNB:** PW - Painted White Aluminum with White Nylon Brush insert

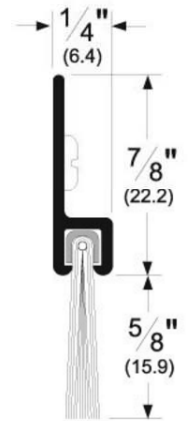



# Garage Door Weather Seal for Top and Side Jambs

## Pemko 45100\_NB Garage/Overhead Door Weatherstrip

Brush Gasketing, 45-Degree

- Brush Perimeter seals are designed to seal the gap between the door and the door jamb. They are surface mounted to the frame and are usually supplied with an angled flange. The angled flange provides the best contact between the brush and the surface of the door.
- This brush gasketing is supplied with a Nylon Brush ("NB") insert - item number P38100 (available in gray and black).
- Item number for Painted White insert is P516100W.

### Ratings

**BHMA** BHMA Certified  
CERTIFIED



Fire Rated - UL10C - Positive Pressure



Underwriters Laboratory 4L10



GREENGUARD Gold Certified

### Finishes



**45100CNB:** C - Clear Anodized Aluminum with Gray Nylon Brush insert



**45100DNB:** D - Dark Bronze Anodized Aluminum with Black Nylon Brush insert



**45100GNB:** G - Gold Anodized Aluminum with Black Nylon Brush insert



**45100PWNB:** PW - Painted White Aluminum with White Nylon Brush insert

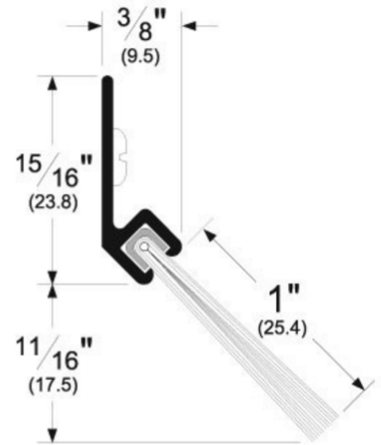

## Garage Door Bottom Weather Seal

### Pemko P364R16 Garage Door Weatherstrip

- Heavy-duty black sponge neoprene ®.
- Nails to door bottom, closing gaps up to 5/8"
- Available in 16 ft. rolls. Larger sizes may be available - please contact customer service.
- Thickness: 3/4"
- Width: 2-1/4"

#### Ratings



Barrier-Free



Fire Rated - UL10C - Positive Pressure



Underwriters Laboratory 4L10

#### Finishes



**P364R:** Black Sponge Neoprene

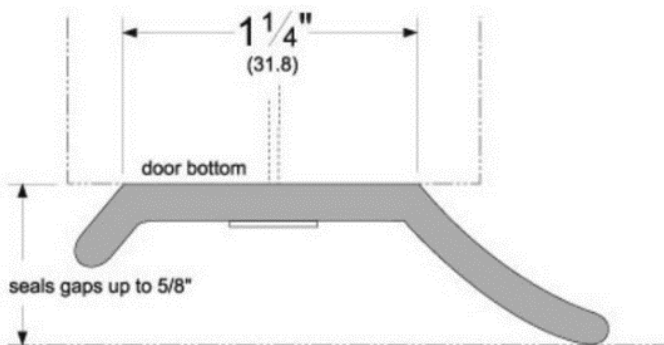

## Attic Access Hatch Weather-Stripping

PRODUCT	SKU	UPC	SPECS	COLOR
<b>D-Section 1/4" Thick - Fits Medium Gaps</b>	V25GA	077578012551	5/16" W, 1/4" T, 17 ft L, D-Section	Grey
	V25BA	077578011776	5/16" W, 1/4" T, 17 ft L, D-Section	Brown
	V25WA	077578011783	5/16" W, 1/4" T, 17 ft L, D-Section	White
	V25BK	077578059228	5/16" W, 1/4" T, 17 ft L, D-Section	Black

